



40 Gb/s Multi-Rate Pluggable Optical Transceivers

*Longer Reach, Increased Port Density,
Reduced Power and Lower Total System
Cost*



10G Optics Are Very Economical Today

- 10G router and switch line cards utilize one of several low-cost transceiver MSAs with 10G serial (e.g. 10GBASE-LR) or CWDM (e.g. 10GBASE-LX4) optics
 - E.g. 10G 300-pin, XENPAK, X2, XPAK, XFP MSAs
- Serial 10G transceiver cost is relatively low
 - Huge investment by industry since late '90s
 - Use mature Silicon CMOS processes
 - Many sources of MSAs and components
 - Cost driven down by competition
 - High-volume: 100s of thousand units per year
- Imminent SFP+ technology expected to lower costs further



40 Gb/s Multi-protocol MSA

10G Modules



300-pin MSA
(76 x 56 x 14)



XENPAK
(121 x 36 x 12)



X2/XPAK
(~76 x 36 x 12/11)



XFP
(75 x 18 x 9)



SFP+
(45 x 13.5 x 8.5)

(Dimensions are indicated as L x W x H in mm)

Electrical Connector	SFP+	20pin	Nothing or	LIA	ROSA
	XFP	30pin	2 x CDR or	DOM	
	XENPAK	70pin	Phy-IC or	LDD	TOSA
	300pin	300pin	Mux/Demux		



10G Services Drives Need for \gg 10G Core Networks

- IP Service Providers now offer multi Gb/s services
 - E.g. OC-192/STM-64 POS and 10 GbE
- Core network typically requires 4-10x bandwidth of highest-speed user service interface to provide adequate performance
- N x 10G LAG (Link Aggregation Group) and ECMP (Equal Cost Multi-Path) deployed today have limitations
 - Reliance on statistical *flow* distribution mechanisms
 - Cannot handle multi Gb/s applications
- True deterministic \geq 40G link technology required



Current 40G Architecture (VSR2000-3R2 Serial Optics)



SFI5 -17x2.5Gb/s

300-pin 40G MSA
177 mm L x 127 mm W x 18mm H

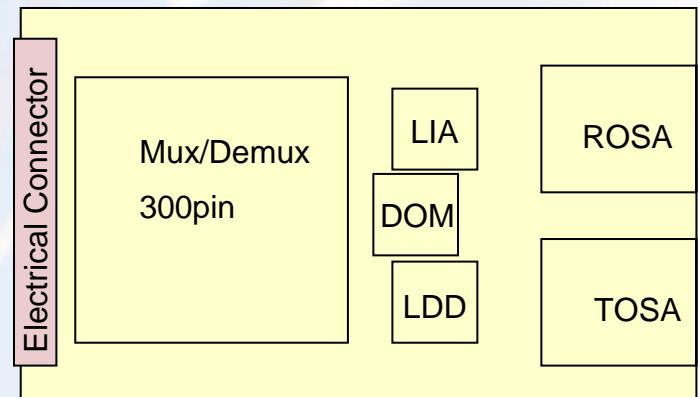



Limitations of Current 40G MSAs (VSR2000-3R2 serial optics)

- Relatively Expensive
 - Higher cost per bit than comparable 10G modules
 - 40G requires more exotic SiGe chips or next-generation Silicon CMOS processes
 - Requires expensive microwave packaging
 - Very low volumes: 1,000s of units per year
 - Very few sources of MSAs and their fundamental components (SerDes, EMLs, etc.)
 - Relatively little investment since 2001 as industry focused on 10G since downturn
- Reach Limitation of only ~ 2 km of SMF
 - Chromatic dispersion limited
- No Hot-Pluggability
- High power (15-20W) and large footprint



How can we leverage the industry's huge investment in 10G optics to lower the cost of 40G?



Low-Cost 10G Technologies

- Several technology developments led to inexpensive 10G transceivers
 - Electrical Interfaces
 - XAUI – 4 x 3.125 Gb/s 10 GbE electrical interface
 - XFI – Serial 10 Gb/s electrical interface
 - Integrated 0.13 μm Silicon CMOS SerDes
 - Optical interfaces
 - 10GBASE-LR – Serial 10 GbE optical interface
 - 10GBASE-LX4 – 4 x 3.125 Gb/s CWDM 10 GbE optical interface
 - Transceiver MSAs
 - XENPAK – Optical transceiver with XAUI interface
 - X2/XPAK – Second-generation XENPAK
 - XFP – Optical transceiver with XFI interface
 - SFP+ – New SFP-like MSA will emerge in 2007



X40 – An Inexpensive 4x 10 Gb/s Transceiver

- Began with a XENPAK 10GBASE-LX4 optical transceiver
- Replaced the XAUI retimer chip and 4x 3.125G TOSA/ROSAs with 4x XFI 10G CDR chips and 4x 10G TOSA/ROSAs
- Retained CWDM optics and XENPAK mechanicals



40 Gb/s Multi-protocol MSA

X40 4x 10G Architecture



4 x XFP



1 x XENPAK@40Gb/s

- Functionality of 4x XFP modules
- Miniaturized into XENPAK form factor
- Utilizes existing technology

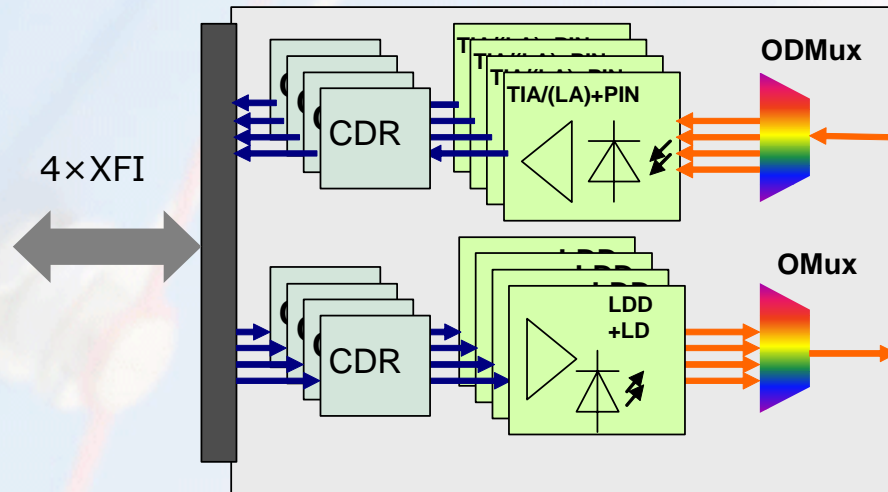



X40 - Benefits

- Lower total system costs
 - Leverage existing 10 Gb/s technologies
- Longer reach
 - 10 km vs. 2 km for 40G serial interface
- Higher line card and port density
 - X40 is 5X smaller than 40G serial MSA
- Lower power consumption
 - $< \frac{1}{2}$ power of 40G serial MSA
- Hot Pluggability
 - Provides flexibility, pay-as-you-grow capability, and operational ease



X40 Optical Interface Specifications

- 4x uncooled CWDM wavelengths around 1310nm
- 10 km reach for short reach metro access links
- Supports standard 10G telecom and datacom protocol payloads per-channel
 - SONET/SDH OC-192/STM-64
 - OTN OTU2
 - Ethernet
- Per-channel data rates:
 - 9.953G (OC-192/STM-64)
 - 10.3125G (10GBASE-R)
 - 10.7G (OTU2)
 - 11.1G (Overclocked OTU2 for 10GBASE-R payload)



Proposed 40G Protocols for 4x 10G Virtual Concatenation

- STS-768/STM-256
 - 4x OC-192 SR1 with CWDM
 - STS-192c-4v Virtual Concatenation
- ODU3
 - 4x OTU2 with CWDM
 - G.709 ODU2-4v Virtual Concatenation
- 40G Ethernet
 - 4x 10GBASE-LR and CWDM
 - Link Aggregation initially
 - IEEE Higher Speed Ethernet Study Group (HSSG) studying Aggregation at the Physical Layer (APL)



Possible Future X40 Technology Directions

- X40
 - 4x 15xx nm wavelengths (CWDM/DWDM)
 - > 40 km reach
 - Electrical interface
 - E.g. Infiniband QDR-style coax cables
 - Parallel optics
 - MTP/MPO connectors
 - Serial 40G VSR2000-3R2 interface
- X40 v2
 - Next-generation SFP+ technology may offer required power reduction to fit into X2 or QSFP MSA packages
- X100
 - X40 electrical and management interfaces future-proofed to allow 5 lanes
 - Upgrade of X40 electrical interface to 20G per lane may be possible
 - 5x 20G CWDM optical interface appears feasible
 - 10x 10G DWDM optical interface already proven



Supporters

